



CME420



Multi-functional current relay, AC,
overcurrent/undercurrent/
window discriminator function



Bender GmbH & Co. KG

P.O. Box 1161 • 35301 Grünberg • Germany

Londorfer Strasse 65 • 35305 Grünberg • Germany

Tel.: +49 6401 807-0 • Fax: +49 6401 807-259

E-Mail: info@bender.de • www.bender.de

© Bender GmbH & Co. KG

All rights reserved.

Reprinting only with permission of the publisher.

Subject to change!

Photos: Bender archives

Table of Contents

1. Important information	5
1.1 How to use this manual	5
1.2 Technical support: service and support	6
1.2.1 First level support	6
1.2.2 Repair service	6
1.2.3 Field service	7
1.3 Training courses	8
1.4 Delivery conditions	8
1.5 Inspection, transport and storage	8
1.6 Warranty and liability	9
1.7 Disposal	10
2. Safety instructions	11
2.1 General safety instructions	11
2.2 Work activities on electrical installations	11
2.3 Intended use	12
2.4 Information about factory setting	12
3. Function	13
3.1 Device features	13
3.2 Function	13
3.2.1 Automatic self test	14
3.2.2 Manual self test	14
3.2.3 Malfunction	14
3.2.4 Specify the number of reload cycles	15
3.2.5 Erasable history memory	15
3.2.6 Assigning alarms to the alarm relays K/1K2	15
3.2.7 Residual current monitoring in window discriminator mode	15
3.2.8 Time delays t , t_{on} and t_{off}	16

3.2.9 Password protection (on, OFF)	16
3.2.10 Factory setting FAC	16
3.2.11 Display accuracy	16
4. Installation and connection	17
5. Operation and setting	19
5.1 Used display elements	19
5.2 Function of the operating elements	20
5.3 Menu structure	21
5.4 Display in standard mode	22
5.5 Display in menu mode	23
5.5.1 Parameter query and setting: overview	23
5.5.2 Switching over from overcurrent to undercurrent operation or to window operation	25
5.5.3 Response value setting for overcurrent:	26
5.5.4 Setting the fault memory and operating principle of the alarm relays	27
5.5.5 Assigning alarm categories to the alarm relays	28
5.5.6 Setting the time delays	30
5.5.7 Changing from overcurrent operation to window operation	31
5.5.8 Setting the transformation ratio for external current transformer	32
5.5.9 Re-establishing the factory settings	34
5.5.10 History memory query	34
5.6 Commissioning	35
5.7 Factory setting	35
5.8 Timing diagram: Current monitoring	36
6. Technical data	37
6.1 Data in tabular form	37
6.2 Standards, approvals and certifications	40
6.3 Ordering information	41

1. Important information

1.1 How to use this manual



*This manual is intended for **qualified personnel** working in electrical engineering and electronics!*

Always keep this manual within easy reach for future reference.

To make it easier for you to understand and revisit certain sections in this manual, we have used symbols to identify important instructions and information. The meaning of these symbols is explained below:



DANGER

*This signal word indicates that there is a **high risk of danger** that will result in **electrocution** or **serious injury** if not avoided.*



WARNING

*This signal word indicates a **medium risk of danger** that can lead to **death** or **serious injury** if not avoided.*



CAUTION

*This signal word indicates a **low level risk** that can result in **minor** or **moderate injury or damage to property** if not avoided.*



*This symbol denotes information intended to assist the user in making **optimum use** of the product.*

1.2 Technical support: service and support

For commissioning and troubleshooting Bender offers you:

1.2.1 First level support

Technical support by phone or e-mail for all Bender products

- Questions concerning specific customer applications
- Commissioning
- Troubleshooting

Telephone: +49 6401 807-760*
Fax: +49 6401 807-259
In Germany only: 0700BenderHelp (Tel. and Fax)
E-mail: support@bender.de

1.2.2 Repair service

Repair, calibration, update and replacement service for Bender products

- Repairing, calibrating, testing and analysing Bender products
- Hardware and software update for Bender devices
- Delivery of replacement devices in the event of faulty or incorrectly delivered Bender devices
- Extended guarantee for Bender devices, which includes an in-house repair service or replacement devices at no extra cost

Telephone: +49 6401 807-780** (technical issues)
+49 6401 807-784**, -785** (sales)
Fax: +49 6401 807-789
E-mail: repair@bender.de

Please send the devices for **repair** to the following address:

Bender GmbH, Repair-Service,
Londorfer Str. 65,
35305 Grünberg

1.2.3 Field service

On-site service for all Bender products

- Commissioning, configuring, maintenance, troubleshooting of Bender products
- Analysis of the electrical installation in the building (power quality test, EMC test, thermography)
- Training courses for customers

Telephone:	+49 6401 807-752**, -762 **(technical issues) +49 6401 807-753** (sales)
Fax:	+49 6401 807-759
E-mail:	fieldservice@bender.de
Internet:	www.bender.de

*Available from 7.00 a.m. to 8.00 p.m. 365 days a year (CET/UTC+1)

**Mo-Thu 7.00 a.m. - 8.00 p.m., Fr 7.00 a.m. - 13.00 p.m

1.3 Training courses

Bender is happy to provide training regarding the use of test equipment. The dates of training courses and workshops can be found on the Internet at www.bender.de -> Know-how -> Seminars.

1.4 Delivery conditions

Bender sale and delivery conditions apply.

For software products the "Softwareklausel zur Überlassung von Standard-Software als Teil von Lieferungen, Ergänzung und Änderung der Allgemeinen Lieferbedingungen für Erzeugnisse und Leistungen der Elektroindustrie" (software clause in respect of the licensing of standard software as part of deliveries, modifications and changes to general delivery conditions for products and services in the electrical industry) set out by the ZVEI (Zentralverband Elektrotechnik- und Elektronikindustrie e. V.) (German Electrical and Electronic Manufacturer's Association) also applies.

Sale and delivery conditions can be obtained from Bender in printed or electronic format.

1.5 Inspection, transport and storage

Inspect the dispatch and equipment packaging for damage, and compare the contents of the package with the delivery documents. In the event of damage in transit, please contact Bender immediately.

The devices must only be stored in areas where they are protected from dust, damp, and spray and dripping water, and in which the specified storage temperatures can be ensured.

1.6 Warranty and liability

Warranty and liability claims in the event of injury to persons or damage to property are excluded if they can be attributed to one or more of the following causes:

- Improper use of the device.
- Incorrect mounting, commissioning, operation and maintenance of the device.
- Failure to observe the instructions in this operating manual regarding transport, commissioning, operation and maintenance of the device.
- Unauthorised changes to the device made by parties other than the manufacturer.
- Non-observance of technical data.
- Repairs carried out incorrectly and the use of replacement parts or accessories not approved by the manufacturer.
- Catastrophes caused by external influences and force majeure.
- Mounting and installation with device combinations not recommended by the manufacturer.

This operating manual, especially the safety instructions, must be observed by all personnel working on the device. Furthermore, the rules and regulations that apply for accident prevention at the place of use must be observed.

1.7 Disposal

Abide by the national regulations and laws governing the disposal of this device. Ask your supplier if you are not sure how to dispose of the old equipment.

The directive on waste electrical and electronic equipment (WEEE directive) and the directive on the restriction of certain hazardous substances in electrical and electronic equipment (RoHS directive) apply in the European Community. In Germany, these policies are implemented through the "Electrical and Electronic Equipment Act" (ElektroG). According to this, the following applies:

- Electrical and electronic equipment are not part of household waste.
- Batteries and accumulators are not part of household waste and must be disposed of in accordance with the regulations.
- Old electrical and electronic equipment from users other than private households which was introduced to the market after 13 August 2005 must be taken back by the manufacturer and disposed of properly.

For more information on the disposal of Bender devices, refer to our homepage at www.bender.de -> Service & support.

2. Safety instructions

2.1 General safety instructions

Part of the device documentation in addition to this manual is the enclosed "Safety instructions for Bender products".

2.2 Work activities on electrical installations



Only **qualified personnel** are permitted to carry out the work necessary to install, commission and run a device or system.



DANGER

Risk of electrocution due to electric shock!

Touching live parts of the system carries the risk of:

- An electric shock
- Damage to the electrical installation
- Destruction of the device

Before installing and connecting the device, make sure that the installation has been *de-energised*. Observe the rules for working on electrical installations.

If the device is used outside the Federal Republic of Germany, the applicable local standards and regulations must be complied with. The European standard EN 50110 can be used as a guide.

2.3 Intended use

The current monitor is designed to monitor the threshold values of AC currents for overcurrent and undercurrent conditions. In case of direct measurement, currents up to 16 A (screw-type terminals) resp. 12 A (push-wire terminals) can be continuously monitored. For indirect measurement by means of a current transformer, a transformation ratio factor up to 2000 can be set. The device allows pure overcurrent and pure undercurrent operation, as well as window operation between two adjustable response values. The device is factory set to overcurrent operation.

In order to meet the requirements of the applicable standards, customised parameter settings must be made on the equipment in order to adapt it to local equipment and operating conditions. Please heed the limits of the range of application indicated in the technical data.

Any use other than that described in this manual is regarded as improper.

2.4 Information about factory setting

The page 35 provides a summary of all factory settings.

If you want to reset the current monitor to factory settings refer to page 34.

3. Function

3.1 Device features

- Undercurrent or overcurrent monitoring in AC systems, $< I$ or $> I$ and current monitoring with window discriminator function
- Indirect current monitoring by means of a current transformer, suitable for transformation ratio factor 1...2000
- Adjustable switching hysteresis
- r.m.s. value measurement AC
- Continuous self monitoring
- Starting delay, response delay and delay on release
- Measured value display via multi-functional LC display
- Alarm indication via LEDs (AL1, AL2) and changeover contacts (K1, K2)
- N/C operation or N/O operation selectable
- Fault memory behaviour selectable
- Password protection against unauthorized parameter changing
- Sealable transparent cover
- Two-module enclosure (36 mm)
- With push-wire terminals: two terminals per connection

3.2 Function

Once the supply voltage is applied, the starting delay "t" is activated. Measured values changing during this time do not influence the switching state of the alarm relays.

The devices provide two separately adjustable measuring channels (overcurrent/undercurrent). When the measured value exceeds (ALARM 1) resp. drops below (ALARM 2) the adjusted threshold value, the time of the response delays " $t_{on 1/2}$ " begins. After the expiry of the response delay, the alarm relays switch and the alarm LEDs light. If the measured value falls below or exceeds the adjusted delay on release (response value plus hysteresis) after the alarm

relays have switched, the delay on release starts " t_{off} ". After the expiry of " t_{off} ", the alarm relays switch back to their initial position. With activated fault memory, the alarm relays do not change their actual state until the reset button R is pressed.

3.2.1 Automatic self test

The device automatically carries out a self test after connecting to the system to be monitored and later every 24 hours. During the self test internal functional faults or connection faults will be determined and will appear in form of an error code on the display. The alarm relays are not checked during this test.

3.2.2 Manual self test

After pressing the internal test button for > 1.5 s, a self test is performed by the device. During this test, internal malfunctions will be determined and appear in form of an error code on the display. The alarm relays are not checked during this test.

While the test button T is pressed and held down, all device-related display elements appear on the display.

3.2.3 Malfunction

In the event of an internal malfunction, all three LEDs flash. An error code appears on the display (E.02...E.32).

Error code	Meaning	Action
E.02	Fault occurred during manual self test	Check device connection. After eliminating the fault, the error code will be automatically deleted.
E.03...E.32		Carry out a reset. Reset the device to factory setting. After eliminating the fault, the error code will be automatically deleted.

If the fault continues to exist, please contact the Bender Service.

3.2.4 Specify the number of reload cycles

If faults occur only temporarily, but recurrently, in the system being monitored, with deactivated fault memory M, the alarm relays would switch synchronously to the error status.

RL in the out menu can be used to limit the number of these changeover processes. As soon as the specified number of processes is exceeded, the fault memory will come on and an activated alarm remains stored.

3.2.5 Erasable history memory

The first alarm value that occurs will be entered in this memory. The memory can be cleared via the menu HiS.

3.2.6 Assigning alarms to the alarm relays K1/K2

Different alarm categories can be assigned to the alarm relays K1/K2 via the menu "out".

3.2.7 Residual current monitoring in window discriminator mode

Change the measuring principle by selecting the window mode (SEt / In). In the window discriminator mode, the threshold values I1 and I2 represent the upper and the lower value. If the measured value is not within this area, an alarm is initiated by the device (see page 31).

3.2.8 Time delays t , t_{on} and t_{off}

The times t , t_{on} and t_{off} described below delay the output of alarms via LEDs and relays.

Starting delay t

After connection to the supply voltage U_S , the alarm indication is delayed by the preset time t (0...300 s).

Response delay $t_{\text{on}1/2}$

If the current value exceeds or falls below the threshold value, the current monitor does not initiate an alarm before the response time t_{an} has elapsed.

A set response delay $t_{\text{on}1/2}$ (0...300 s) adds up to the device-related operating time t_{ae} and delays alarm signalling (total delay time $t_{\text{an}} = t_{\text{ae}} + t_{\text{on}}$).

If the fault does not continue to exist before the time of the response delay has elapsed, an alarm will not be indicated.

Release delay t_{off}

When no alarm exists after deactivating the fault memory, the alarm LEDs will go out and the alarm relays switch back to their initial position. After activating the release delay (0...300 s), the alarm state is continuously maintained for the selected period.

3.2.9 Password protection (on, OFF)

With activated password protection (on), settings can only be carried out when the correct password (0...999) has been entered.

3.2.10 Factory setting FAC

After activating the factory setting, all settings previously changed are reset to delivery status.

3.2.11 Display accuracy

The display accuracy of the measured current values depends on the set response values. When an alarm response value I2 of 10 A has been selected, currents smaller than 350 mA are displayed as < 0.3 A.

4. Installation and connection



Only **qualified personnel** are permitted to carry out the work necessary to install, commission and run a device or system.



DANGER

Risk of electrocution due to electric shock!

Touching live parts of the system carries the risk of:

- An electric shock
- Damage to the electrical installation
- Destruction of the device

Before installing and connecting the device, make sure that the installation has been de-energised. Observe the rules for working on electrical installations.

Dimension diagram and drawing for screw fixing

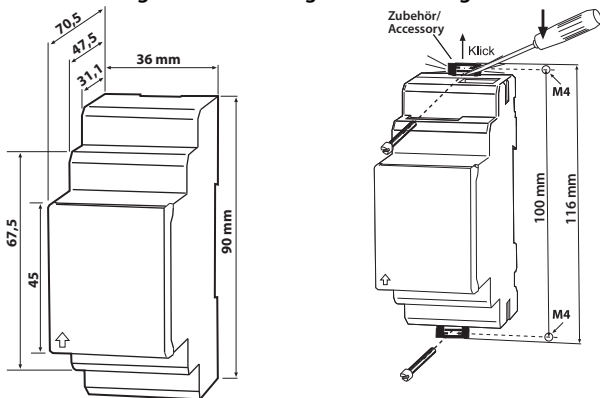

The front plate cover is easy to open at the lower part identified by an arrow.

1. DIN rail mounting:

Snap the rear mounting clip of the device into place in such a way that a safe and tight fit is ensured.

Screw fixing:

Use a tool to move the rear mounting clips (a second mounting clip required, see ordering information) to a position that it projects over the enclosure. Then fix the device using two M4 screws.

2. Wiring

Connect the device according the wiring diagram.

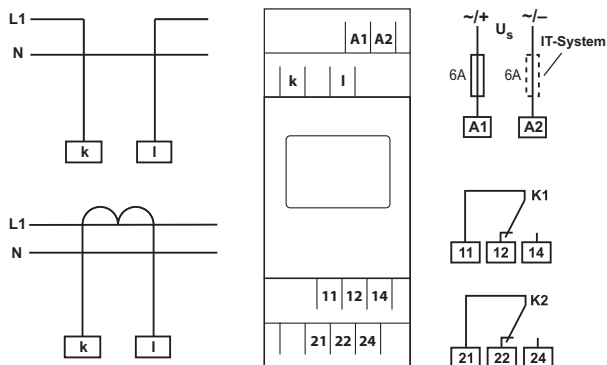



Terminal	Connections
A1, A2	Connection to supply voltage U_s
k, l	Connection to the conductor to be monitored: directly or by means of a current transformer
11, 12, 14	Alarm relay K1
21, 22, 24	Alarm relay K2

5. Operation and setting

5.1 Used display elements

A detailed description of the meaning of the display elements is given in the table below.



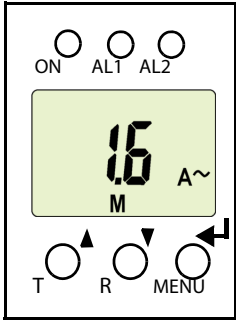

Used display elements	Element	Function
	RL	Reload function with memory = off (L = I.)
	n	Transformation ratio factor for external current transformer
	<I >I	Undercurrent Overcurrent
	r1, 1 r2, 2	Alarm relay K1, Alarm relay K2
	I Hys, %	Response value hysteresis in %
	ton1, ton2, t, toff	Response delay t_{on1} (K1), Response delay t_{on2} (K2) Starting delay t, Delay on release t_{off} for K1, K2
	M	Fault memory active
		Operating mode of the relays K1, K2
		Password protection active

5.2 Function of the operating elements

Device front	Element	Function
	ON	Power On LED, green
	AL1, AL2	LED Alarm 1 lights (yellow): Response value 1 reached LED Alarm 2 lights (yellow): Res- ponse value 2 reached
	1,6 A, M	I = 1.6 A flow via the terminals k and l, Fault memory active
	T, ▲	Test button (> 1.5 s): Indication of the display elements, starting a self test; Up key (< 1.5 s): Menu items/values
	R, ▼	Reset button (> 1.5 s): Deleting the fault memory; Down key (< 1.5 s): Menu items/values
	MENU, ◀	MENU key (> 1.5 s): Starting the menu mode; Enter key (< 1.5 s): Confirm menu item, submenu item and value. Enter key (> 1.5 s): Back to the next higher menu level.

5.3 Menu structure

All adjustable parameters are listed in the columns menu item and adjustable parameters. A display-like representation is used to illustrate the parameters in the column menu item. Different alarm categories can be assigned to the alarm relays K1, K2 via the submenus r1, r2. This is done by activation or deactivation of the respective function.

Menu	Sub menu	Menu item	Activation	Adjustable parameter
AL (response - values)		> I2	ON (HI)	Overcurrent (alarm)
		> I1	ON (HI)	Overcurrent (prewarning)
		Hys		Hysteresis < I21, > I21
out (output control)		M	ON	Fault memory
		 1	-	Operat. mode K1 (n.c.)
		 2	-	Operat. mode K2 (n.c.)
		RL		Reload function (memory = off)
	r1 (K1: (assignment alarm category))	1 Err	ON	Device error at K1
		r1 I1	ON	Prewarning I1 at K1
		r1 I2	OFF	Alarm I2 at K1
		1 tES	ON	Device test
	r2 (K2: (assignment alarm category))	2 Err	ON	Device error at K2
		r2 I1	OFF	Prewarning I1 at K2
		r2 I2	ON	Alarm I2 at K2
		2 tES	ON	Device test
	t (timing check)		t on 1	-
t on 2			-	Response delay K2
T			-	Starting delay
t off			-	Delay on release K1/K2

Menu	Sub menu	Menu item	Activation	Adjustable parameter
Set (device control)	→	I 12	HI	Setting ranges: High, window function, low
		n	1	Transformation ratio factor external current transformer
			OFF	Parameter setting via password
		FAC	-	Re-establish factory settings
		SYS	-	Function blocked
InF	→	-	-	Display hard / software version
HiS	→	Clr	-	History memory for the first alarm value, eras- able

5.4 Display in standard mode

By default, the currently measured current is displayed or, if required, the measured overcurrent value. The current response values (**prewarning**) and I2 (**alarm**) can be displayed using the **Up and Down key**. If you want to return to the measured value, press the **Enter key**.

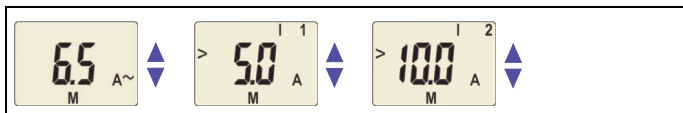

5.5 Display in menu mode

5.5.1 Parameter query and setting: overview

Menu item	Adjustable parameter
AL	Response values query and setting: <ul style="list-style-type: none"> – Alarm I2 (AL2), (undercurrent, overcurrent or window function can be set in the SEt/I menu) – Prewarning I1 (AL1), (50 % of I2) – Specify the hysteresis of the response values: Hys I12
out	Configuration of the fault memory and the alarm relays: <ul style="list-style-type: none"> – Activating/deactivating the fault memory – Select N/O operation (n.o.) or N/C operation (n.c.) individually for each K1/K2 – Specify the number of the reload cycles – Assign the alarm categories undercurrent or overcurrent or device error individually to each K1/K2 (1, r1 / 2, r2).
T	Delay settings: <ul style="list-style-type: none"> – Response delay t_{on1}/t_{on2} – Starting delay t – Delay on release t_{off} (LED, relay)
SEt	Parameter setting for device control: <ul style="list-style-type: none"> – Select the appropriate parameter for response values: High (HI), low (Lo) or window function (In). – Set the transformation ratio (n) for the current transformer – Enable or disable password protection, change the password – Re-establish factory settings – Service menu SyS blocked
InF	Query hard and software version
HiS	Query the first stored alarm value
ESC	Move to the next higher menu level (back)

Menu structure

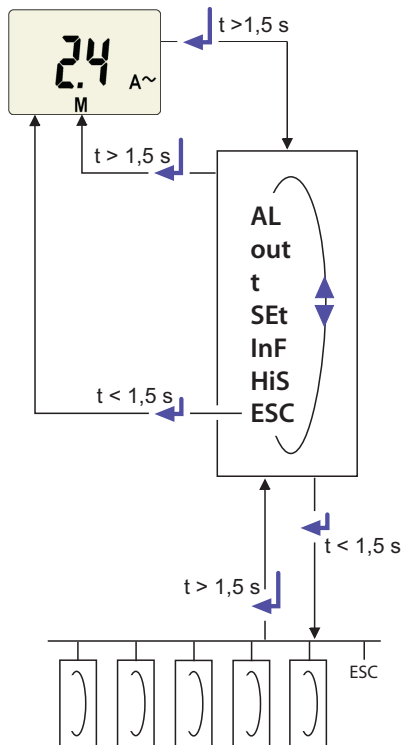

Parameter settings

An example is given below on how to change the alarm response value for overcurrent > I1. It is presumed that the option overcurrent (HI) has been selected in the SEt/I menu (factory setting). Proceed as follows:

1. Press the MENU/Enter key for more than 1.5 seconds. The flashing short symbol AL appears on the display.
2. Confirm with Enter. The parameter response value I2 flashes, in addition the associated overcurrent value > 10.0 A appears.
3. Use the Down key to select the parameter response value I1. The parameter I1 flashes, in addition the associated percentage value for prewarning 50 % of I2 appears.
4. Confirm with Enter. The current value for prewarning appears on the flashing display.
5. Use the Up or Down key to set the appropriate response value. Confirm with Enter. I1 flashes.
6. You can exit the menu by:
 - Pressing the Enter key for more than 1.5 seconds to reach the next higher level or
 - selecting the menu item ESC and confirming with Enter to reach the next higher level.



The currently active segments are flashing! In the figures below, the segments where device settings can be carried out are highlighted by an oval. The menu mode can be reached by pressing the MENU key for more than 1.5 seconds.

5.5.2 Switching over from overcurrent to undercurrent operation or to window operation

The operating mode can be selected in the SEt/I menu using the parameters HI, Lo and In. By default, overcurrent operation (HI) is set. Refer to page 31 for a detailed description on how to switchover to the window mode.

5.5.3 Response value setting for overcurrent:

- Response value I2 (overcurrent)
- Response value I1 (overcurrent)
- Hysteresis (Hys) of the response values I1, I2

Increasing the response value I2 (Example: overcurrent)

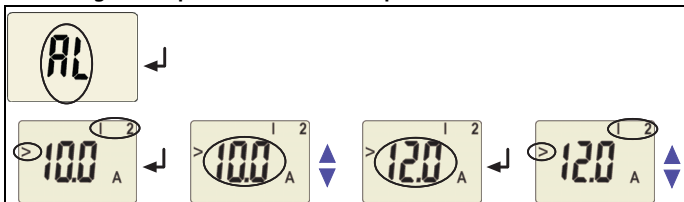

Increasing the response value I1 (prewarning overcurrent)

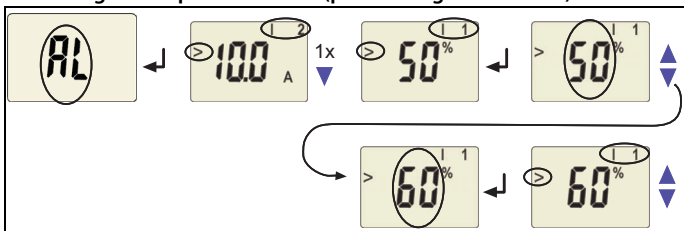

Setting the hysteresis of the response value

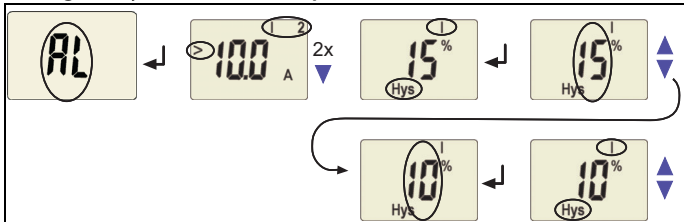

5.5.4 Setting the fault memory and operating principle of the alarm relays

Deactivating the fault memory

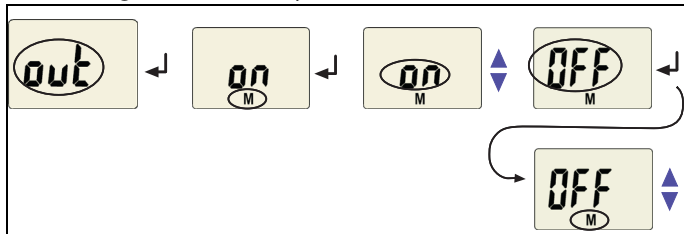

Setting the alarm relay K1 to N/O operation (n.o.)

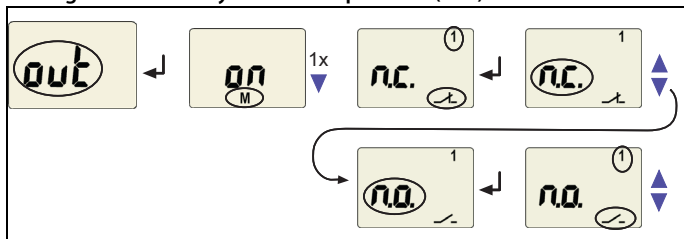

Setting the number of reload cycles

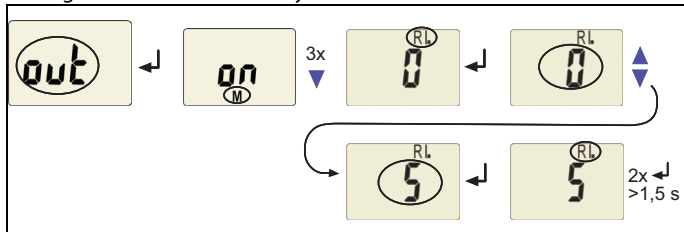

5.5.5 Assigning alarm categories to the alarm relays

Overcurrent, undercurrent and device-related errors of the current monitor can be assigned to the alarm relays K1 (r1, 1) and K2 (r2, 2). By default, the alarm relays K1 and K2 signal prewarning and alarm in case of overcurrent.

Alarm relay K1: Deactivating the category device error

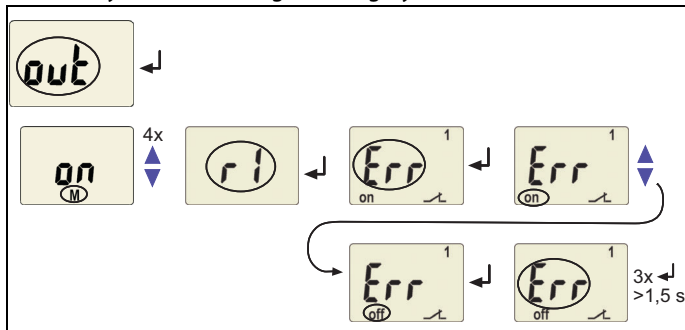

Alarm relay K1: Deactivating the category response value I1

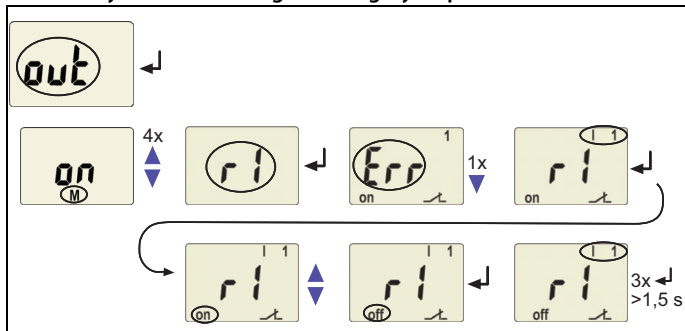

Alarm relay K1: Activating the category response value I2

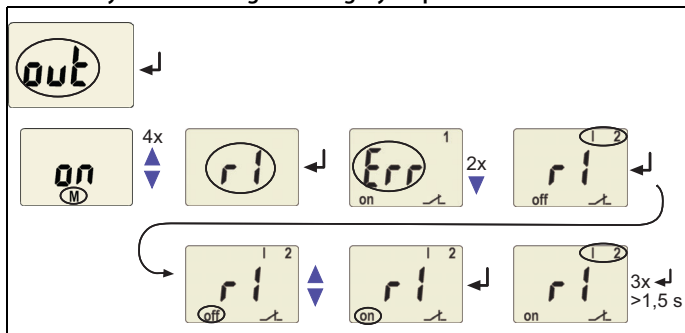

Alarm relay K1: Deactivating the category device test

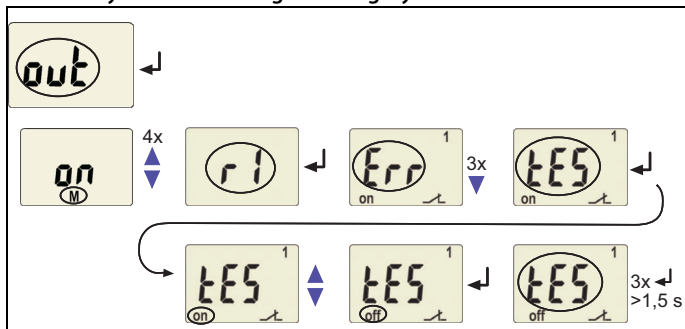

CAUTION

When an alarm relay (K1/K2) has been deactivated in the menu, an alarm will not be signalled by the respective changeover contact! An alarm will only be indicated by the respective alarm LED (AL1/AL2)!

5.5.6 Setting the time delays

The following delays can be specified:

- Response delay t_{on1} (0...300 s) for K1, and t_{on2} (0...300 s) for K2
- Starting delay t (0...10 s) when the device is being started
- Common delay on release t_{off} (0...300 s) for K1, K2. The setting t_{off} is only relevant when the fault memory M is deactivated.

The operating steps for the setting of the response delay t_{on1} and the starting delay t are illustrated by way of example.

Setting the response delay t_{on1}

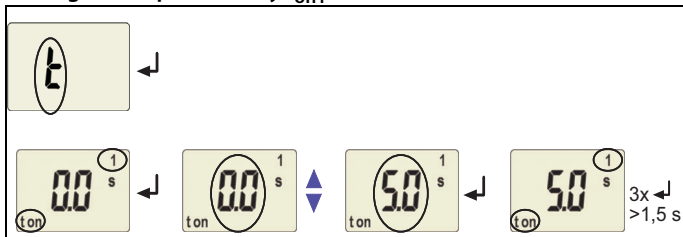

Setting the starting delay t

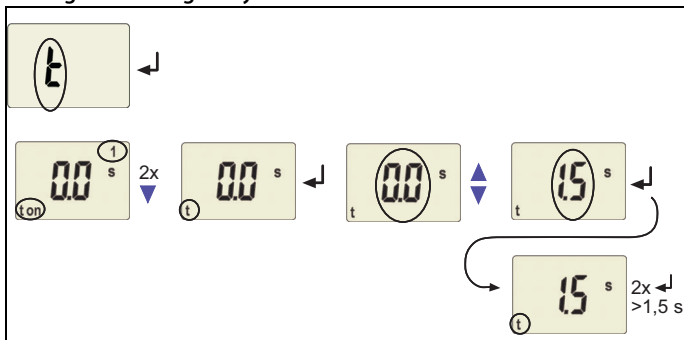

5.5.7 Changing from overcurrent operation to window operation

Use this menu item to set whether the response values of the device apply to overcurrent (HI) or undercurrent operation (Lo). In addition, window operation (In) can be selected.

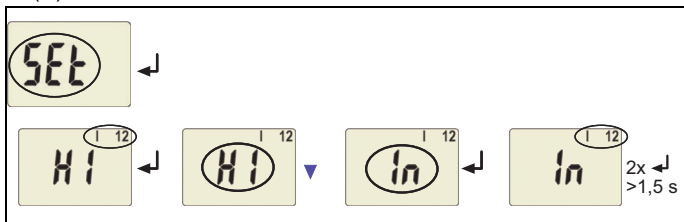

5.5.8 Setting the transformation ratio for external current transformer

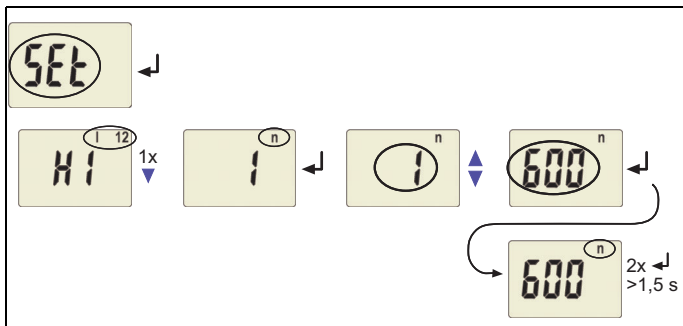

Factory setting and password protection

Use this menu to activate the password protection, to change the password or to deactivate the password protection. In addition, you can reset the device to its factory settings.

a) Activating the password protection

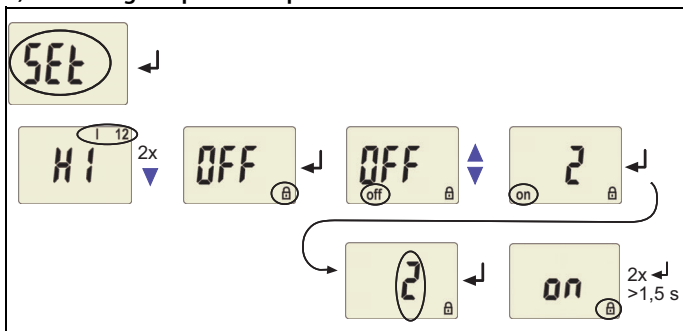

b) Changing the password

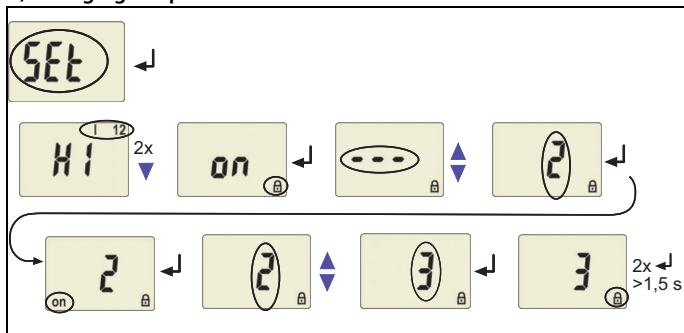

c) Deactivating the password protection

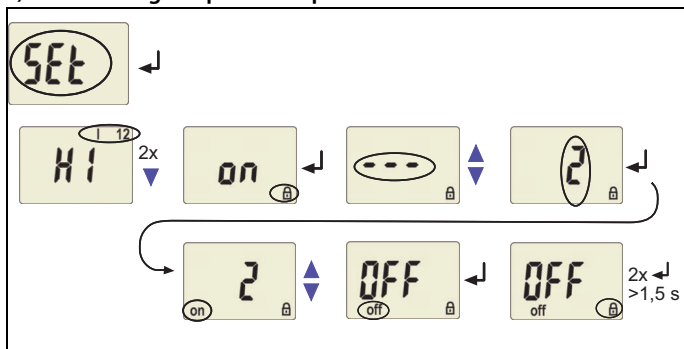

5.5.9 Re-establishing the factory settings

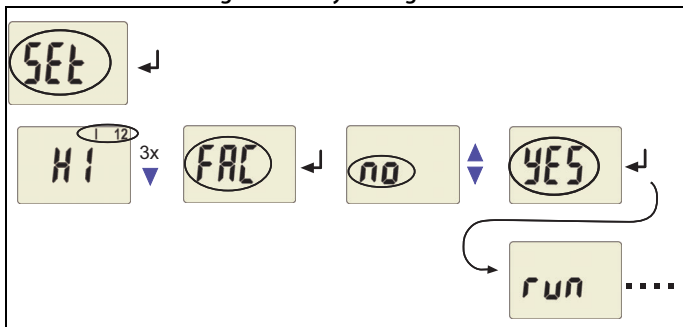

Device information query

This function is used to query the hardware (d...) and software (1.xx) versions. After activating this function, data will be displayed as a scrolling text. Once one pass is completed you can select individual data sections using the Up/Down keys.

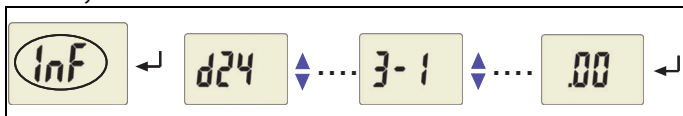

5.5.10 History memory query

The history memory can be selected via the menu HiS. Use the Up and Down keys to view the next display. If Clr is flashing, the history memory can be cleared by pressing the Enter key.

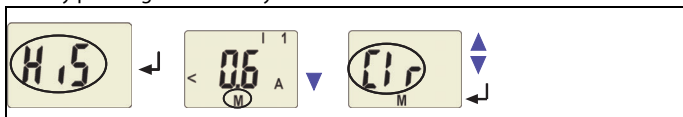

5.6 Commissioning

Prior to commissioning, check proper connection of the current relay.



DANGER

Danger of fire!

Please note the **maximum permissible measuring current** continuously applied is in case of direct measurement:

Push-wire terminals: 12 A

Screw-type terminals: 16 A

5.7 Factory setting



Response value overcurrent I1 (prewarning)	5 A (50 % of I2)
Response value overcurrent I2 (alarm)	10 A
Hysteresis:	15 %
Fault memory M:	activated (on)
Operating mode K1/K2	N/C operation (n.c.)
Starting delay:	$t = 0,5 \text{ s}$
Response delay:	$t_{on1} = 1 \text{ s}$
	$t_{on2} = 0 \text{ s}$
Release delay:	$t_{off} = 1 \text{ s}$
Password:	0, deactivated (Off)

5.8 Timing diagram: Current monitoring

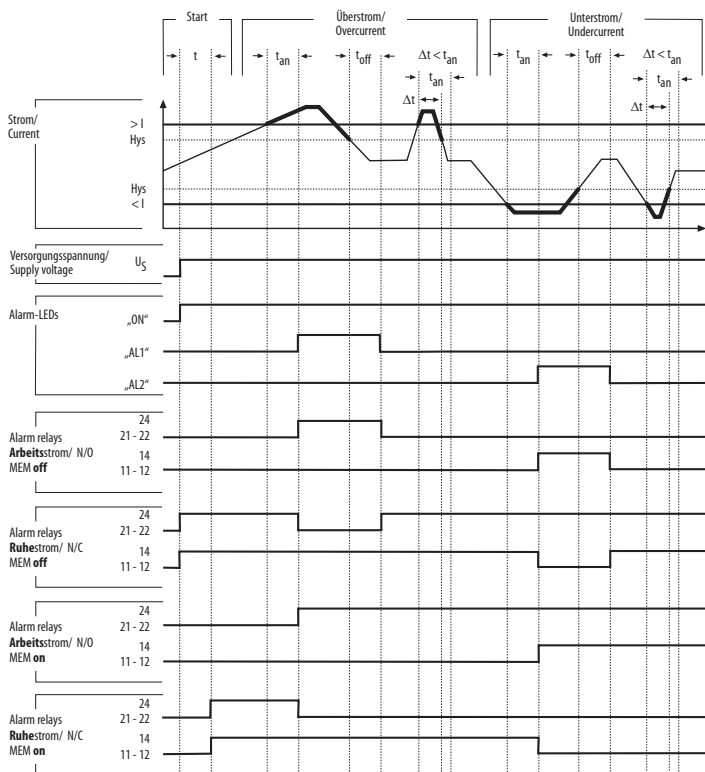

t = Starting delay, t_{an} = Response time, t_{off} = Delay on release

6. Technical data

6.1 Data in tabular form

()* = factory setting

Insulation coordination acc. to IEC 60664-1/IEC 60664-3

Rated insulation voltage	250 V
Rated impulse voltage/overvoltage category.....	4 kV/III
pollution degree	3
Protective separation (reinforced insulation) between.....	(A1, A2) - (k, l) - (11, 12, 14) - (21, 22, 24)
Maximum nominal voltage of the system being monitored when the conductor being monitored is directly connected:	
With protective separation.....	AC 230 V
Without protective separation	AC 400 V

Supply voltage

CME420-D-1:

Supply voltage U_s	AC 16...72 V/DC 9.6...94 V
Frequency range U_s	42...460 Hz

CME420-D-2:

Supply voltage U_s	AC/DC 70...300 V
Frequency range U_s	42...460 Hz
Power consumption	≤ 4 VA

Measuring circuit

Measuring range (r.m.s. value, screw-type terminal)	AC 0.05...16 A
Measuring range (r.m.s. value, push-wire terminal)	AC 0.05...12 A
Overload capability < 1 s	40 A
Rated frequency f_n	42...460 Hz

Response values

Undercurrent

Undercurrent < I (alarm I_2), direct connection:

Push-wire terminal.....	AC 0.1...12 A (1 A)*
-------------------------	----------------------

Screw-type terminal or external current transformer	AC 0.1 ... 16 A (1 A)*
Undercurrent < I (prewarning I ₁)	100 % ... 200 % (150 %)*

Overcurrent

Overcurrent > I (alarm I ₂), direct connection:	
Push-wire terminal	AC 0.1 ... 12 A (1 A)*
Screw-type terminal or external current transformer	AC 0.1 ... 16 A (1 A)*
Overcurrent > I (prewarning I ₁)	10 % ... 100 % (50 %)*

Others

External current transformer.....	x/1 A, x/5 A, x/10 A
Transformation ratio factor n	1 ... 2000 (1)*
Relative percentage error at 50 Hz/60 Hz	±3 %, ±2 digits
Relative percentage error in the range of 42 ... 2000 Hz.....	±5 %, ±2 digits
Hysteresis	10 ... 40 % (15 %)*

Specified time

Starting delay	0 ... 300 s (0.5 s)*
Response delay t _{on1}	0 ... 300 s (1 s)*
Response delay t _{on2}	0 ... 300 s (0 s)*
Delay on release t _{off}	0 ... 300 s (1 s)*
Operating time t _{ae}	≤ 70 ms
Response time t _{an}	t _{an} = t _{ae} + t _{on1/2}
Recovery time t _b	≤ 300 ms

Displays, memory

Display	LC display, multi-functional, not illuminated
Measuring range measured value x transformation ratio factor.....	AC 0.01 ... 16 A x n
Operating error at 50 Hz/60 Hz	±3 %, ±2 digits
Operating error in the range of 42 ... 2000 Hz.....	±5 %, ±2 digits
Measured-value memory (HiS) for the first alarm value.....	data record measured values
Password	Off/0 ... 999 (Off)*
Fault memory (M) alarm relay	on/off (on)*

Switching elements

Number	2 relays, with one changeover contact each (K1, K2)				
Operating principle	N/C operation n.c./N/O operation n.o. (N/C operation n.c.)*				
Electrical service life under rated operating conditions	10 000 switching operations				
Contact data acc. to IEC 60947-5-1:					
Utilization category	AC-13	AC-14	DC-12	DC-12	DC-12
Rated operational voltage	230 V	230 V	24 V	110 V	220 V
Rated operational current	5 A	3 A	1 A	0.2 A	0.1 A
Minimum contact load	1 mA at AC/DC \geq 10 V				

Environment/EMC

EMC	IEC 61326
Operating temperature	-25 °C ... +55 °C
Classification of climatic conditions acc. to IEC 60721:	
Stationary use (IEC 60721-3-3)	3K23 (except condensation and formation of ice)
Transportation (IEC 60721-3-2)	2K11 (except condensation and formation of ice)
Storage (IEC 60721-3-1)	1K22 (except condensation and formation of ice)
Classification of mechanical conditions acc. to IEC 60721:	
Stationary use (IEC 60721-3-3)	3M11
Transportation (IEC 60721-3-2)	2M4
Storage (IEC 60721-3-1)	1M12

Option "W" data different from the standard version

Classification of climatic conditions acc. to IEC 60721:	
Stationary use (IEC 60721-3-3)	3K23 (condensation and formation of ice is possible)
Classification of mechanical conditions acc. to IEC 60721:	
Stationary use (IEC 60721-3-3)	3M12

Connection

Connection	screw-type terminals
Connection properties:	
rigid/flexible	0.2 ... 4/0.2 ... 2.5 mm ² /AWG 24 ... 12
Multi-conductor connection (2 conductors with the same cross section):	
rigid/flexible	0.2 ... 1.5 mm ² /0.2 ... 1.5 mm ²
Stripping length	8 ... 9 mm
Tightening torque	0.5 ... 0.6 Nm

Connection	push-wire terminals
Connection properties:	
rigid	0.2 ... 2.5 mm ² /AWG 24... 14
flexible without ferrule	0.75 ... 2.5 mm ² /AWG 19... 14
flexible with ferrule	0.2 ... 1.5 mm ² /AWG 24... 16
Stripping length	10 mm
Opening force	50 N
Test opening, diameter	2.1 mm

Other

Operating mode	continuous operation
Position	any position
Degree of protection DIN EN 60529, internal components	IP30
Degree of protection DIN EN 60529, terminals	IP20
Enclosure material	polycarbonate
Flammability class	UL94 V-0
DIN rail mounting acc. to	IEC 60715
Screw fixing	2 x M4 with mounting clip
Weight	≤ 160 g

(*) = factory setting

6.2 Standards, approvals and certifications



6.3 Ordering information

Device type	Supply voltage U_s^*	Response value	Art. No.
CME420-D-1 (screw-type terminal)	DC 9.6 V...94 V / AC 42...460 Hz, 16...72 V	0.1...16 A x n	B93060001 B93060001W
CME420-D-1 (push-wire terminal)	DC 9.6 V...94 V / AC 42...460 Hz, 16...72 V	0.1...12 A x n	B73060001 B73060001W
CME420-D-2 (screw-type terminal)	DC 70...300 V / AC 42...460 Hz, 70...300 V	0.1...16 A x n	B93060002 B93060002W
CME420-D-2 (push-wire terminal)	DC 70...300 V / AC 42...460 Hz, 70...300 V	0.1...12 A x n 0.1...12 A x n	B73060002 B73060002W
*Absolute values of the voltage range			
Mounting clip for screw fixing (1 piece per device, accessories)			B98060008

INDEX

A

Adjustable parameters, list 21
Automatic self test 14

D

Deleting the fault alarms 20
Device features 13
Display in standard mode 22

E

Enter key 20
Example of parameter setting 25

F

factory setting 16, 35
Function 13

H

How to use this manual 5

I

Installation and connection 17
Intended use 12

K

K1: assignment alarm category 21
K2: assignment alarm category 21

L

LED Alarm 1 lights 20
LED Alarm 2 lights 20

M

Malfunction 14
Manual self test 14
Menu

- AL (response values) 21
- HiS (history memory for the first alarm value) 22
- InF (hard and software version) 22
- out (output control) 21
- Set (device control 22
- t (timing check) 21

Menu structure, overview 21
Mounting clip for screw fixing 41

O

Operating elements, function 20
Operation and setting 19
Ordering information 41

P

Parameter query and setting, overview 23

Parameter setting

- Activating or deactivating the password protection 32
- Assigning alarm categories to the alarm relays 28
- Changing from overcurrent operation to window operation 31
- Deactivating the fault memory 27
- Response value setting 26
- Setting the time delay 30

Password protection 16

R

Release delay toff 16

Reset button 20

Response delay ton 16

Response value setting

- Hysteresis 26
- Overcurrent ($> I$) 26

S

Service 6

Setting the number of reload cycles 27

Starting delay t 16

Starting the menu mode 20

Support 6

T

Technical data 37

Test button 20

Training courses 8

U

Used display elements 19

W

Wiring diagram 18

Work activities on electrical installations 11
workshops 8



Bender GmbH & Co. KG

P.O. Box 1161 • 35301 Grünberg • Germany
Londorfer Strasse 65 • 35305 Grünberg • Germany
Tel.: +49 6401 807-0 • Fax: +49 6401 807-259
E-Mail: info@bender.de • www.bender.de

Photos: Bender archives



BENDER Group